

Aim: This guideline explains how to identify load restraint “Rated” Curtains. It provides general advice on the correct ways to use them as part of a load restraint system.

The Law:

Australian road transport law requires that loads are properly restrained for transport. The diagram to the right shows expected forces. These forces result from cornering, stopping, accelerating, and emergency situations.

Load Rated Curtains ONLY restrain sideways. If the load is also restrained from moving forwards and backwards, then the load may be considered contained. For fully contained loads, which cannot move horizontally, limited vertical movement is permissible under the upwards force.

Severe penalties apply, not only for drivers, but also those who instruct or are responsible for the driver’s or loader’s actions.

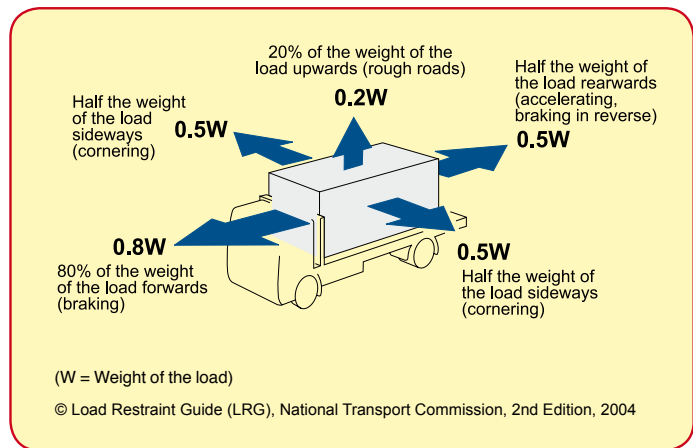

Rated Curtains for Load Restraint:

For many loads and situations, Rated Curtains are a great solution. They usually save drivers time and manual labour, by eliminating gates along the side of the truck or trailer. However some drivers and loaders misunderstand their use and limitations. Rated Curtains are part of the overall load restraint solution, which usually include a rated headboard and tailboard too. In some cases, additional lashings may be required to restrain heavy items of freight, or to make up for large gaps in the load.

Are all Curtains Rated?

NO! This Guideline explains how to identify load restraint “Rated” Curtains and the correct ways to use them as part of your overall load restraint.

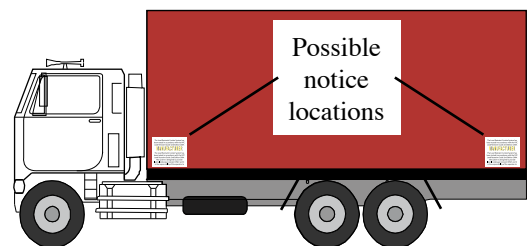

How to tell if a Curtain is Rated?

Either:

- The curtain has a certificate attached explaining the curtain rating.
- Or the driver must carry and produce a certificate when required by road authorities and any party in the chain of responsibility.

Note: The rating may be invalid if any part of the curtain system is damaged. Check regularly for damage.

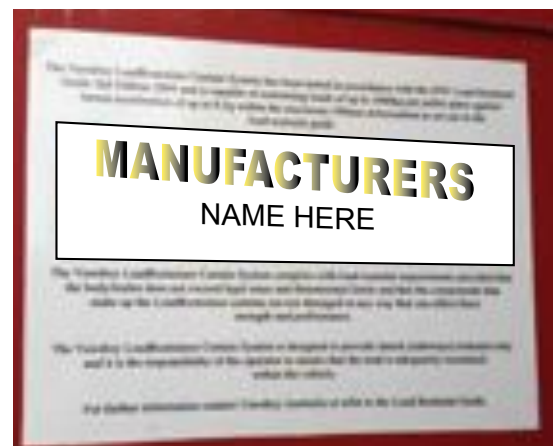

Understanding the Rating of Curtains

Ratings are stated as either:

- Allowable weight per pallet width
(So mass of pallet A + pallet B must be less than Rating)

OR

- Allowable weight per pallet space
(So mass of pallet A or B must be less than Rating)

OR

- Total payload of evenly distributed pallets over entire deck space.

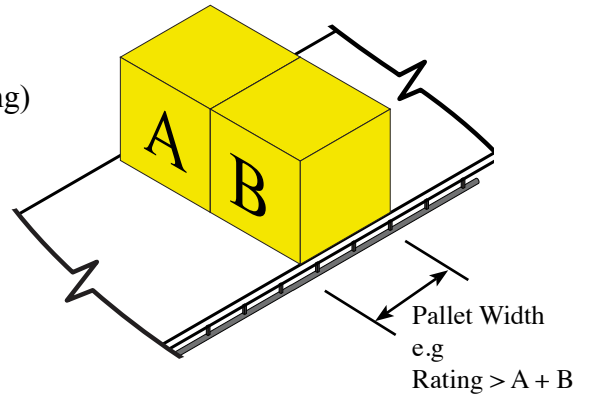

When are rated curtains not suitable?

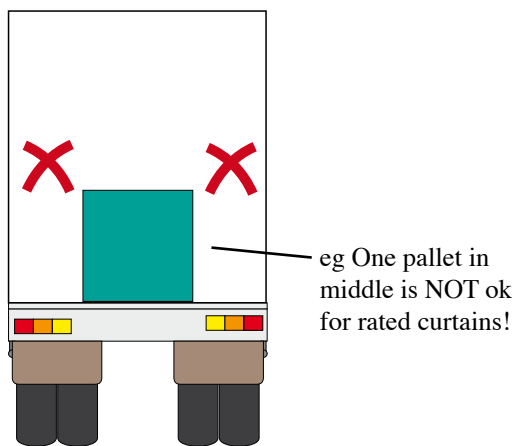

Gaps must not exceed a total of 100 mm

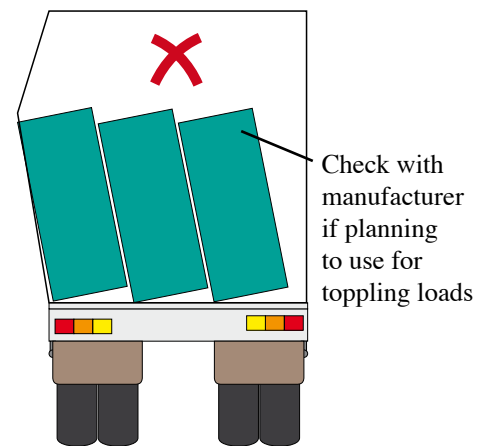

Toppling loads



Heavy individual item with sharp edges

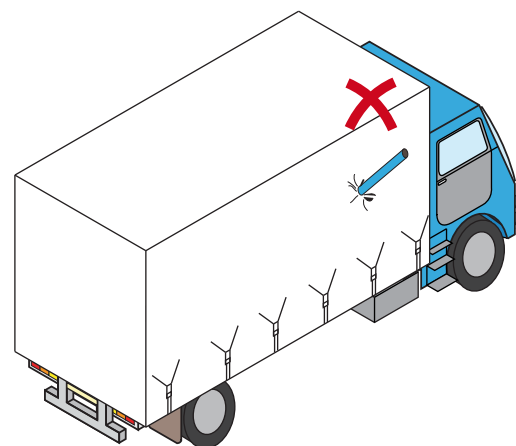

Heavy "SPEAR" type loads like steel bars or pipes which could pierce the curtain

Good Loads, Mistakes & Solutions

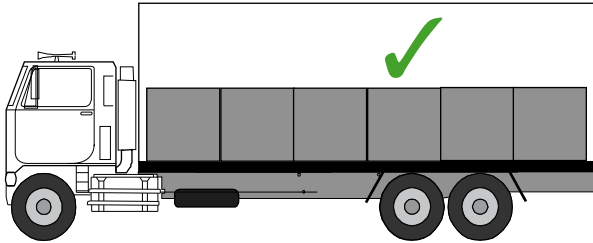

Whole load as single drop

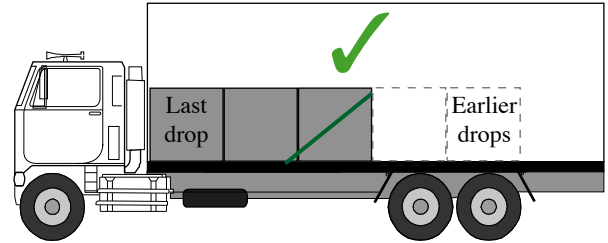

Multi drop, rear restrained for 0.5 g of load

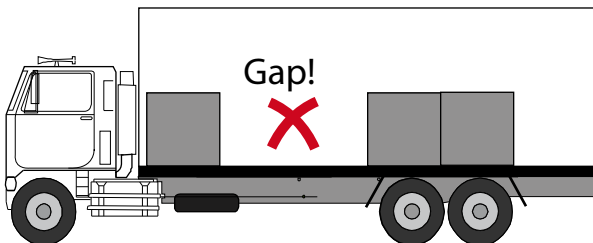

Curtains only restrain sideways.
Rear and forward also need restraint

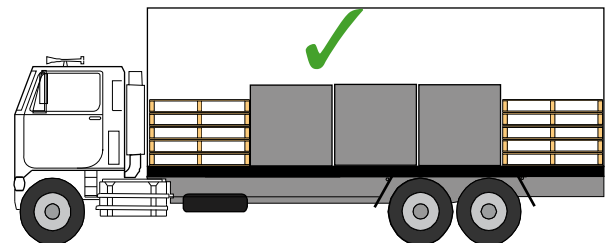

Load blocked front and rear with pallets
Total gaps must be less than:
200 mm forwards;
100 mm sideways.

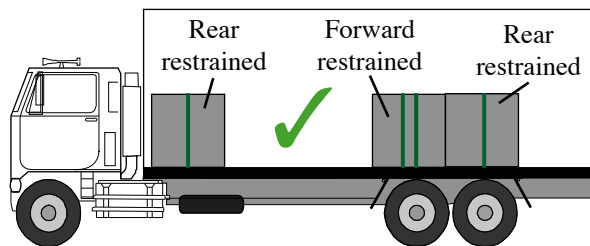

Extra lashings against forward & rearward forces

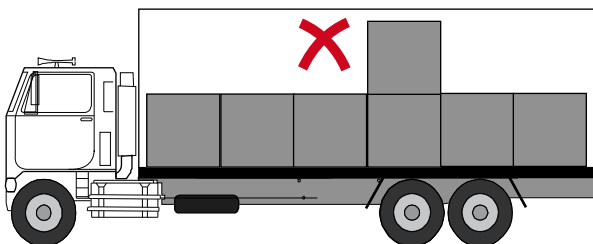

Upper pallet will require load restraint to stop forward and rearward movement

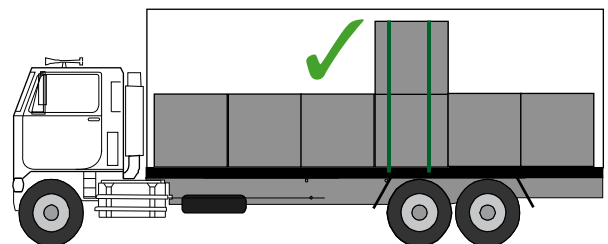

Multi layer pallets



Confirm with manufacturer that curtains are capable of:

- Stacked loads
- Mezzanine loads

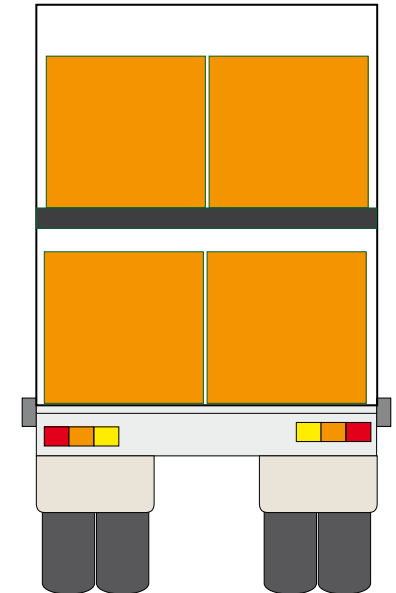
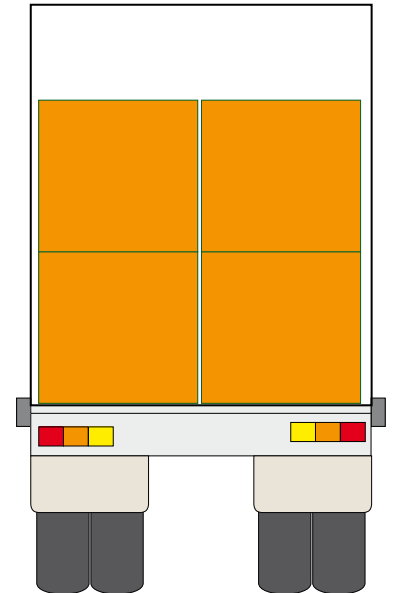

If curtains are capable of stacked & mezzanine loads, add weights of both layers when checking curtain capacity.

Individual box delivery truck, eg beverage truck

Check with body manufacturer to confirm if individual boxes on load rated curtains is acceptable.

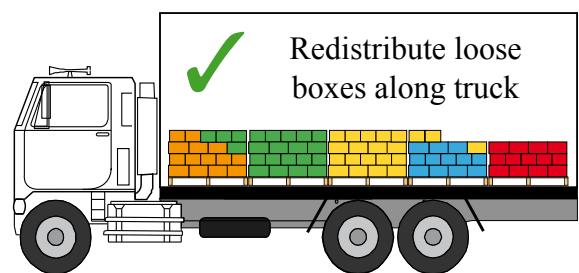
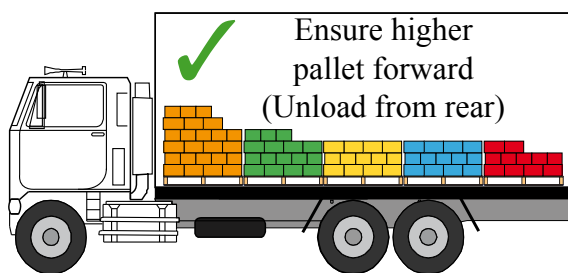

Always check with manufacturer before using curtains for individual boxes.

Opening & Closing Curtains



If bulging curtain on one side, open the other side and assess the risk

Note: A badly bulging curtain may also make you liable for a fine for an over width load.

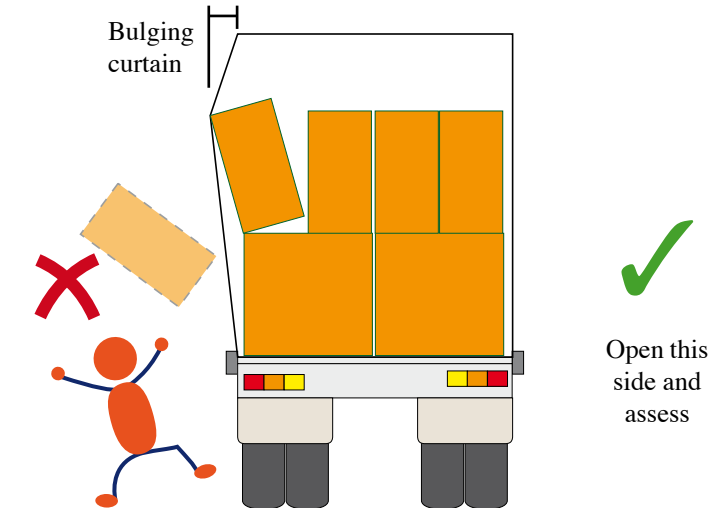

Gap so rear bundles need securing or blocking

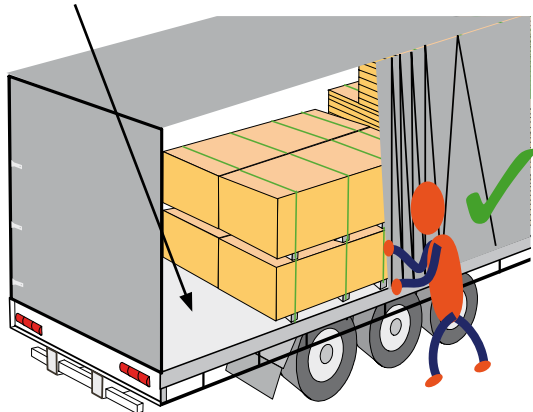

Good:

- Grip with two hands and bent elbows facing towards side of vehicle.
- Pull curtain in smooth action.
- Release grip, move further up the trailer, adjust stance and repeat action.

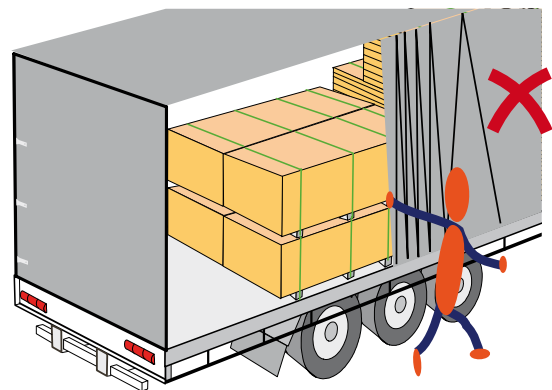

Bad:

- One arm pulling across your body.
- Walking quickly with curtain.
- Shoulder or elbow ligament injury and/or torn muscles in your side if it jams or snags.

Queries should be directed to:

The Program Manager Safety, Australian Logistics Council.

Tel: (02) 6273 0755 Email: peter.elliott@austlogistics.com.au

This note has been produced to provide assistance and guidance only, and compliance with the law and relevant standards is your responsibility. It remains your responsibility to ensure the equipment load restraint methods are appropriate for the individual circumstances.